

FRONT LINKAGE

NEW

FSK-18

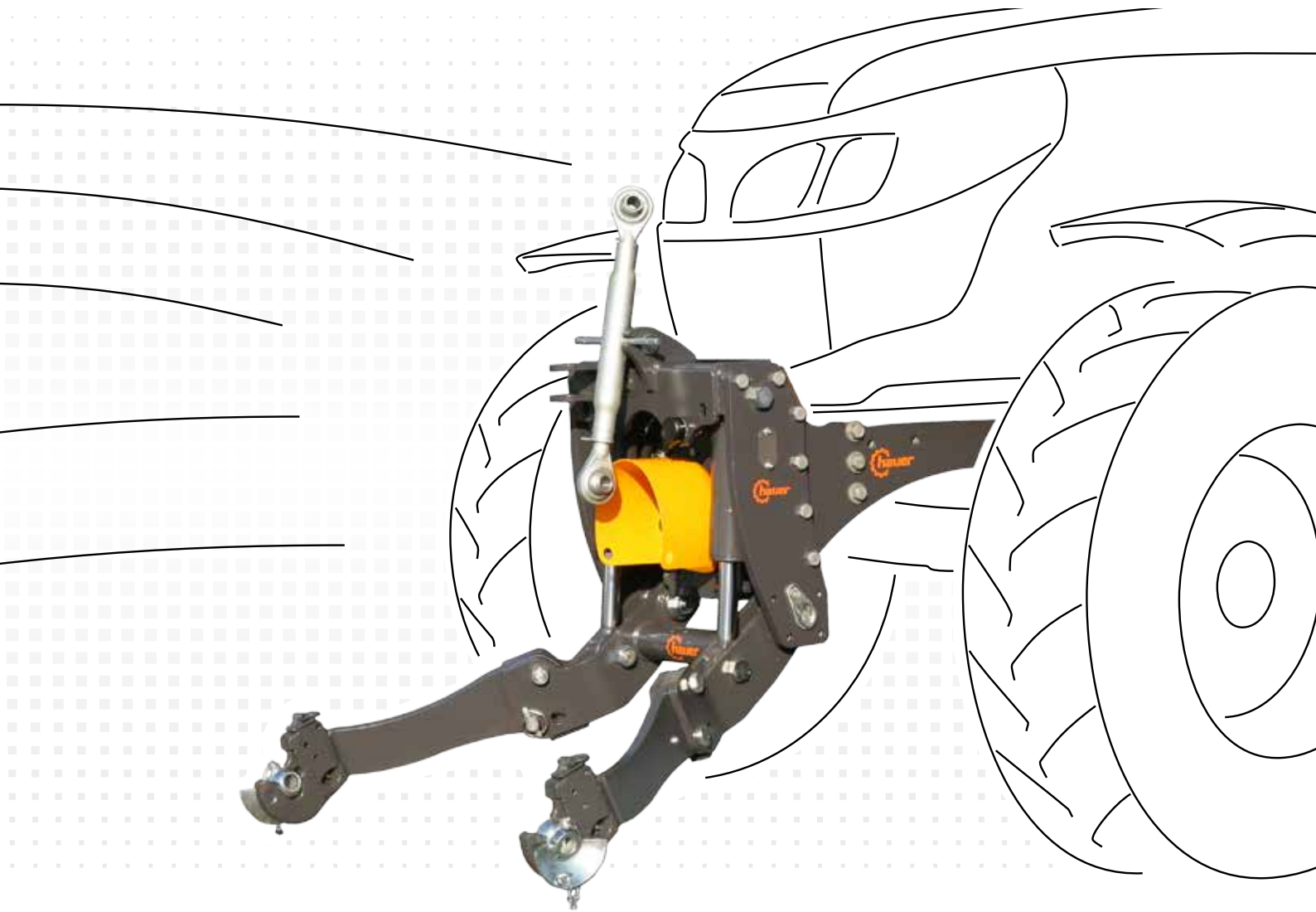

...technology, that moves



compact - versatile - robust

The front linkage "FSK-18" has been developed by Hauer especially for the tractor segment up to approximately 70HP. Compact design, large ground clearance and rigid construction are the particular advantages of the front linkage. Great attention was given of course to the compatibility of the front power take-off shafts from the existing sales program. The fixed screwed front linkage essentially consists of two components. The coupling brackets the respective tractor model and the front linkage itself. Both are screwed together to form a rigid unit. The lower control arms are arranged slanted and can be folded up as required. In this parking position they are ideally placed and provide enough visibility for the driver and space for an attached front loader.



front linkage FSK-18 with good ground clearance

Technical data:

type	category / hook	lifting force	recommended tractor power	weight, without brackets
		kg	hp	kg
FSK-18	2 / 2	1800	up to 70	157

Specifications are approximate and not binding - they can vary depending on the equipment.
Technical data is subject to change.

Franz Hauer GmbH & CoKG

A-3125 Statzendorf, Werksstraße 6

Tel.: +43 / (0)2786 / 7104-0

Fax: +43 / (0)2786 / 7104-15

e-mail: info@hfl.co.at; Internet: www.hfl.co.at



Serial equipment:

- lower control arms can be folded up and removed
- Walterscheid – quick couplings
- pendulum compensation, lockable
- double-acting lifting cylinders
- ball joint bearing on the lifting cylinders
- shut-off valve in the lifting line
- integrated coupling device
- upper control arms
- hydraulic supply line inside
- preparation for lighting-socket
- preparation for additional lines in the cross-pipe
- preparation for electrical telecontrol of the front linkage

Optional equipment:

- additional lines integrated in the cross pipe
- lighting socket
- electrical telecontrol of the front linkage (electrical preparation has to be on the tractor)
- multi-function valve for lifting cylinder double-acting / single-acting switchable
- hydraulic accumulator – shock absorbers
- holder plates for relief springs